

MANUFACTURER GUIDELINES:
AIBA OFFICIAL RING

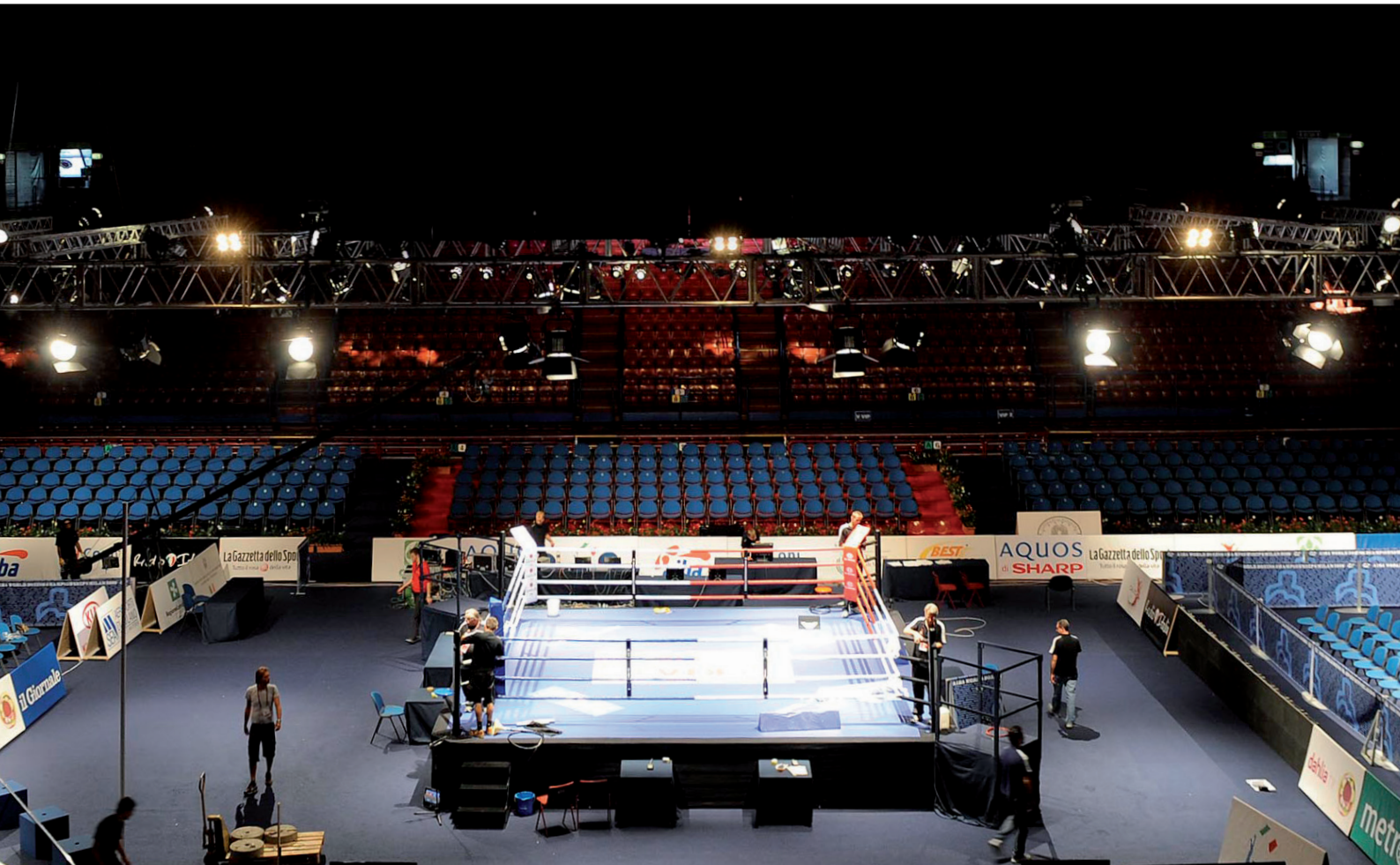
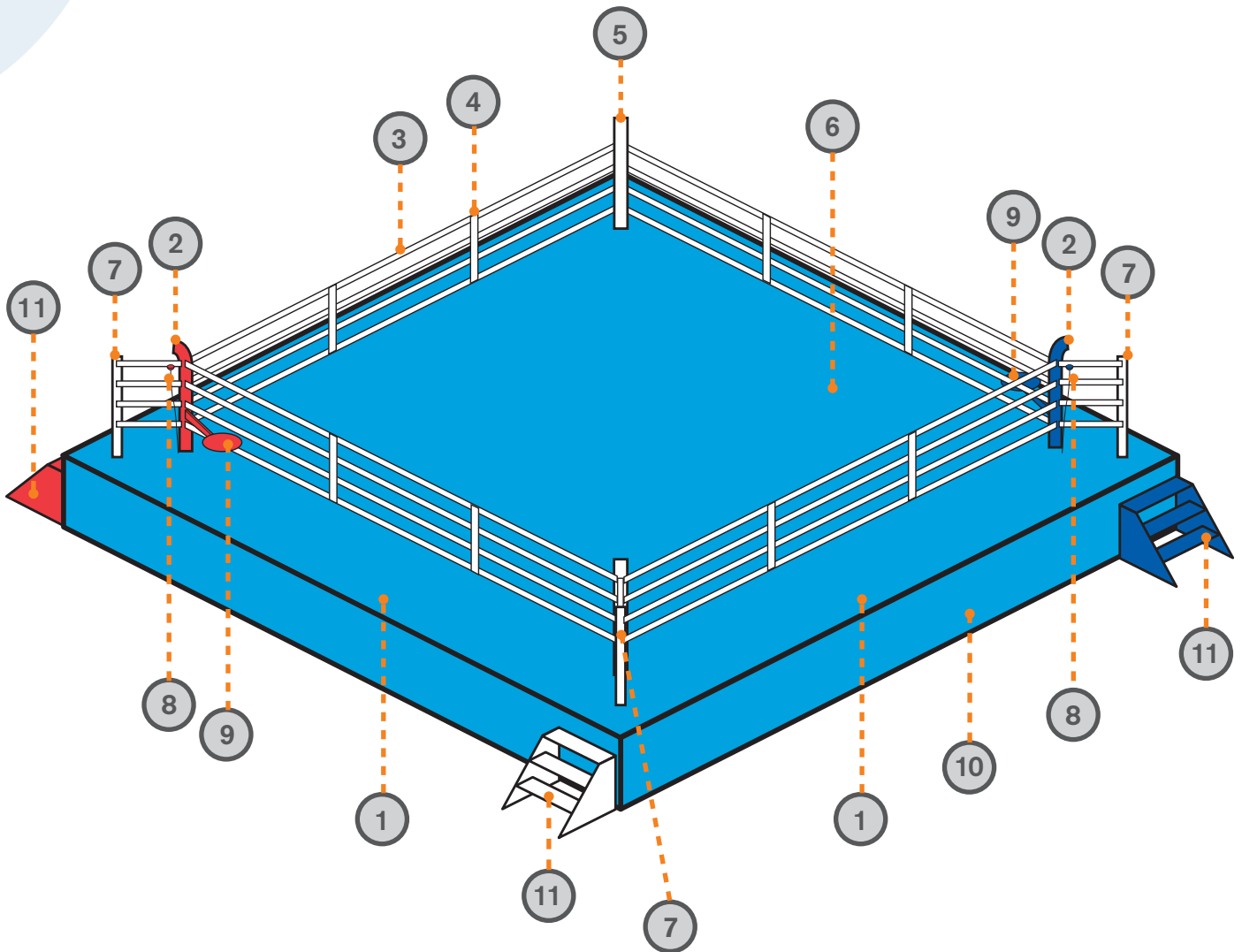

TABLE OF CONTENTS

RING DEFINITIONS.....	3
Canvas.....	4
Apron	5
Skirts	6
Corner Pad	7
Poles	8
Ropes	9
Rope Stripes	10
Stairs	11
Corners' Chair	12
Spit Containers	13
Logos and Prints	14
Storing Bags	15
Assembly Guidelines	16

RING DEFINITIONS



- 1: Apron
- 2: Boxer's Corner Pad
- 3: Ropes
- 4: Stripes
- 5: Neutral Corner Pad
- 6: Canvas

- 7: Poles
- 8: Spit Containers
- 9: Corner's Chairs
- 10: Ring Skirts
- 11: Stairs

CANVAS

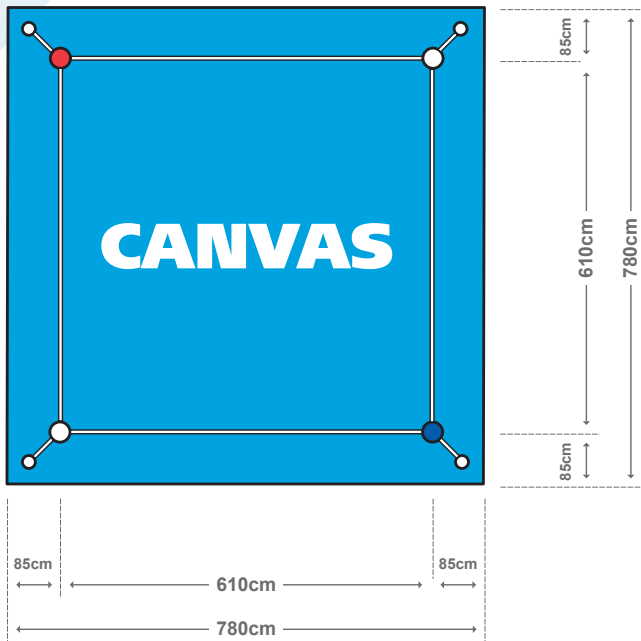

CANVAS SPECIFICATIONS:

- For all AIBA Competitions, the ring must be 6.10m square inside the line of the ropes
- The ring must have the dimensions set out in the diagram
- The canvas must cover the entire platform and must be made of non-slippery material
- **The canvas must be blue, pantone 299**

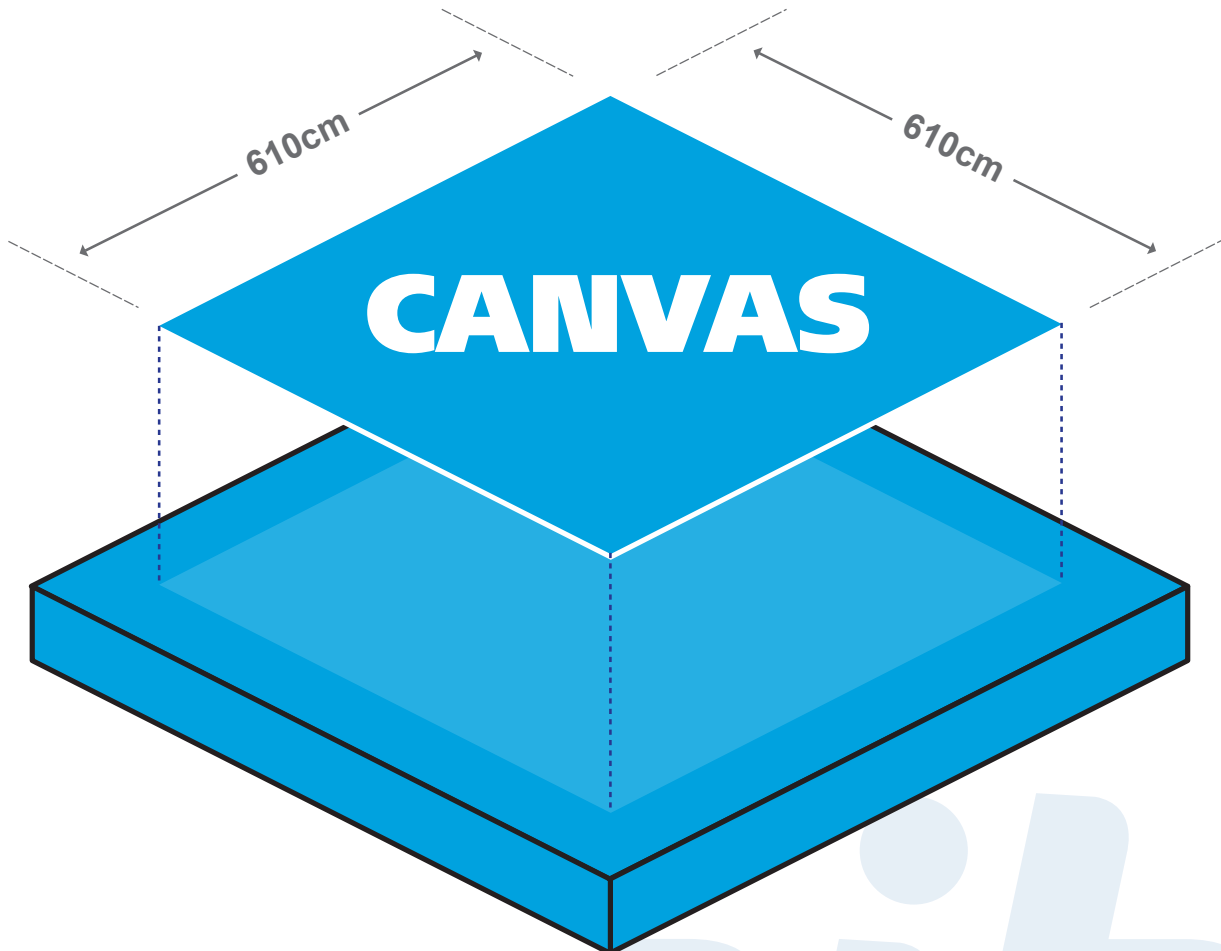

APRON

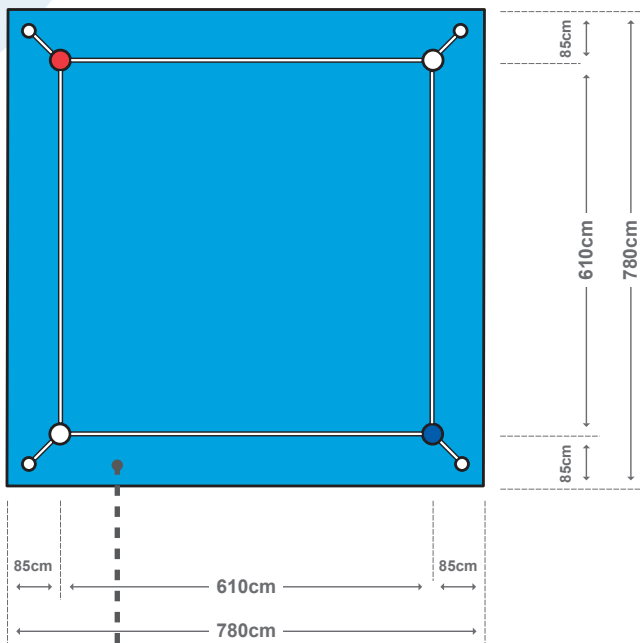

APRON SPECIFICATIONS:

- The size of the apron must extend for 85cm outside the line of the ropes on each side. However, the total size should be long enough to cover the edge of the ring to be connected with the skirts – around 10cm wider, for a total of 800 x 800 cm
- **The color of the aprons should be blue, pantone 299**
- The Apron shall be a non-slippery material such as 18 ounces cotton canvas (18 oz/sq yard)
- The floor must be covered with felt, rubber or other suitably approved material that is soft quality and elasticity. It must not be less than 1.5cm and no more than 2.0cm

APRON

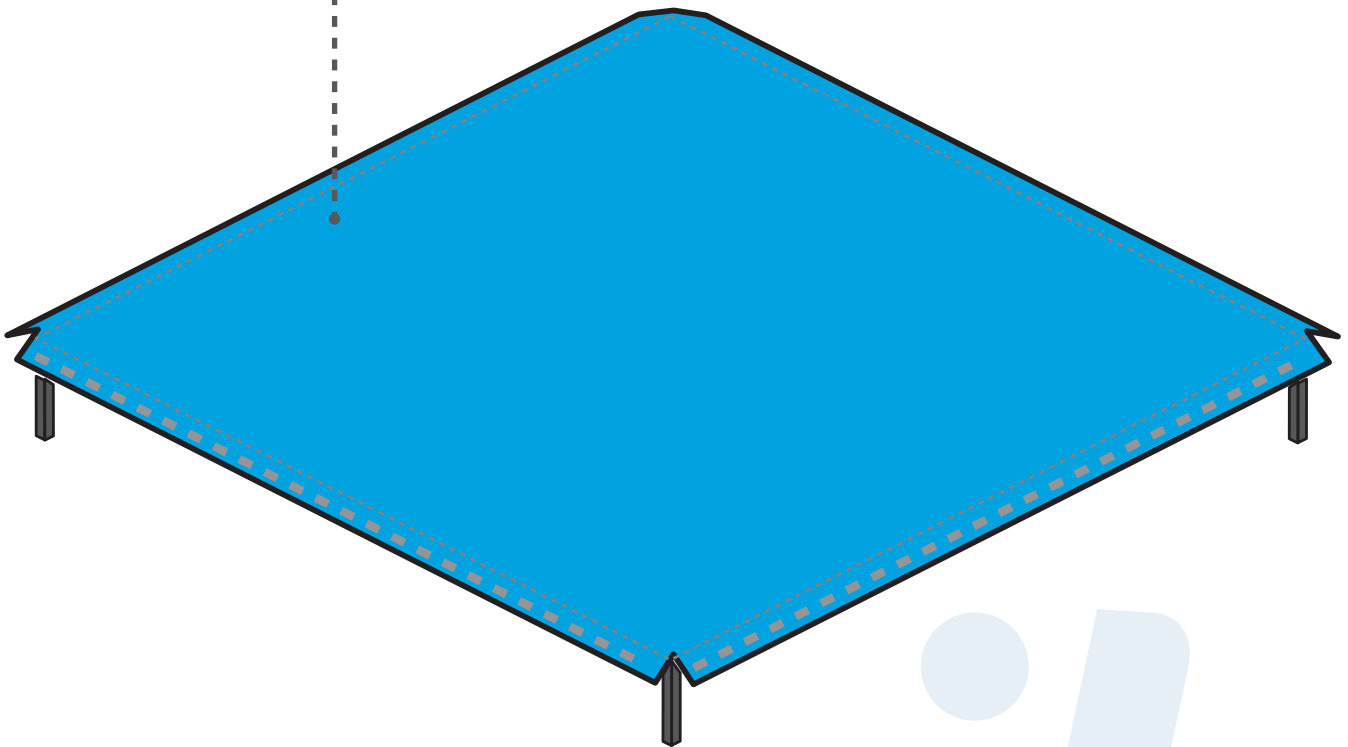

RING SKIRTS

RING SKIRTS SPECIFICATIONS:

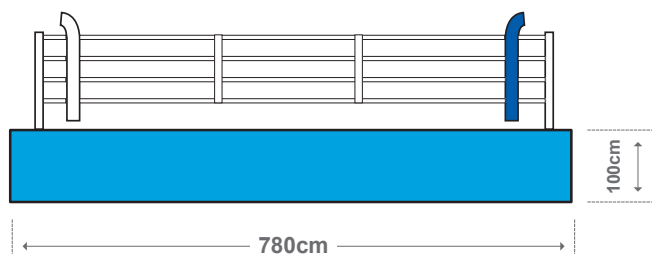

- The color of all skirts should be blue, pantone 299
- The height of each skirt should be 1m
- The material of the skirts should be Tapoline
- All skirts should be separately connected by Velcro – should not be made of one long skirt with 31m20, but 4 separate 7m80
- The edge of the aprons and the top of the skirts should also be connected with Velcro

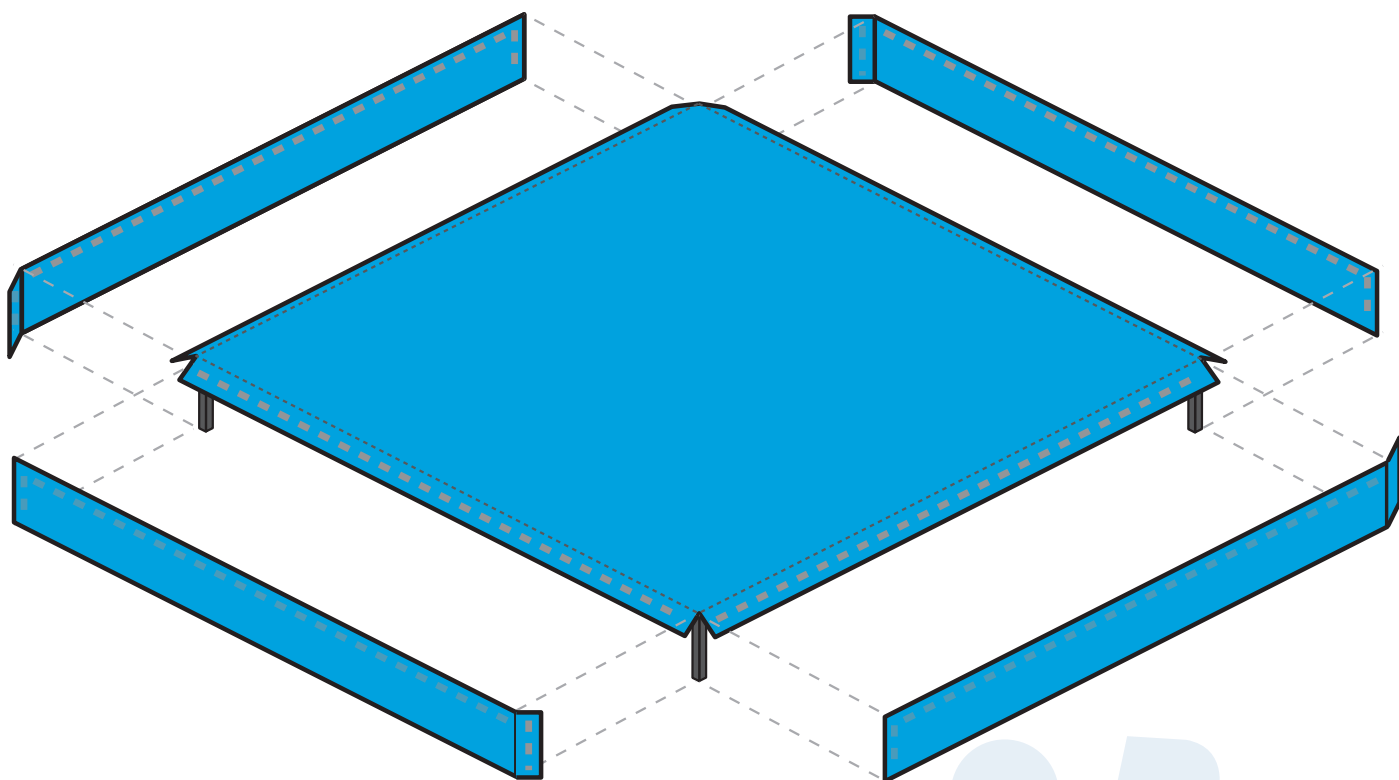

CORNER PAD

CORNER PAD SPECIFICATIONS:

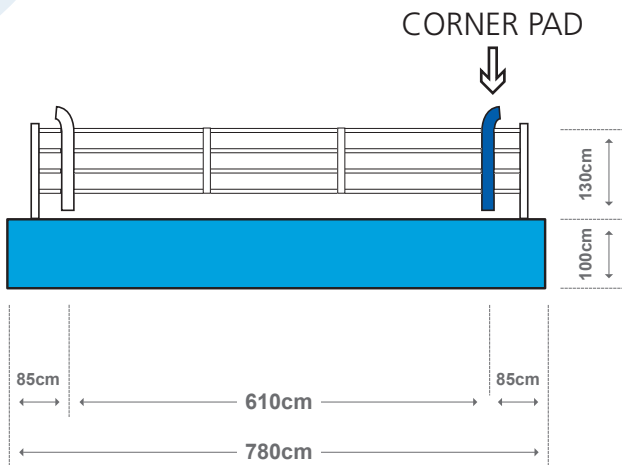

- The material of the pads' cover should be Tapoline
- The inside of the corner pads should consist of foam and steel
- There should be three different colored pads
 - 1 Red corner which should be red (185C)
 - 1 Blue corner which should be blue (286C)
 - 2 Neutral corners which should be white
- The corner pads should not touch the canvas or the aprons
- The length of the corner pads should cover all ropes

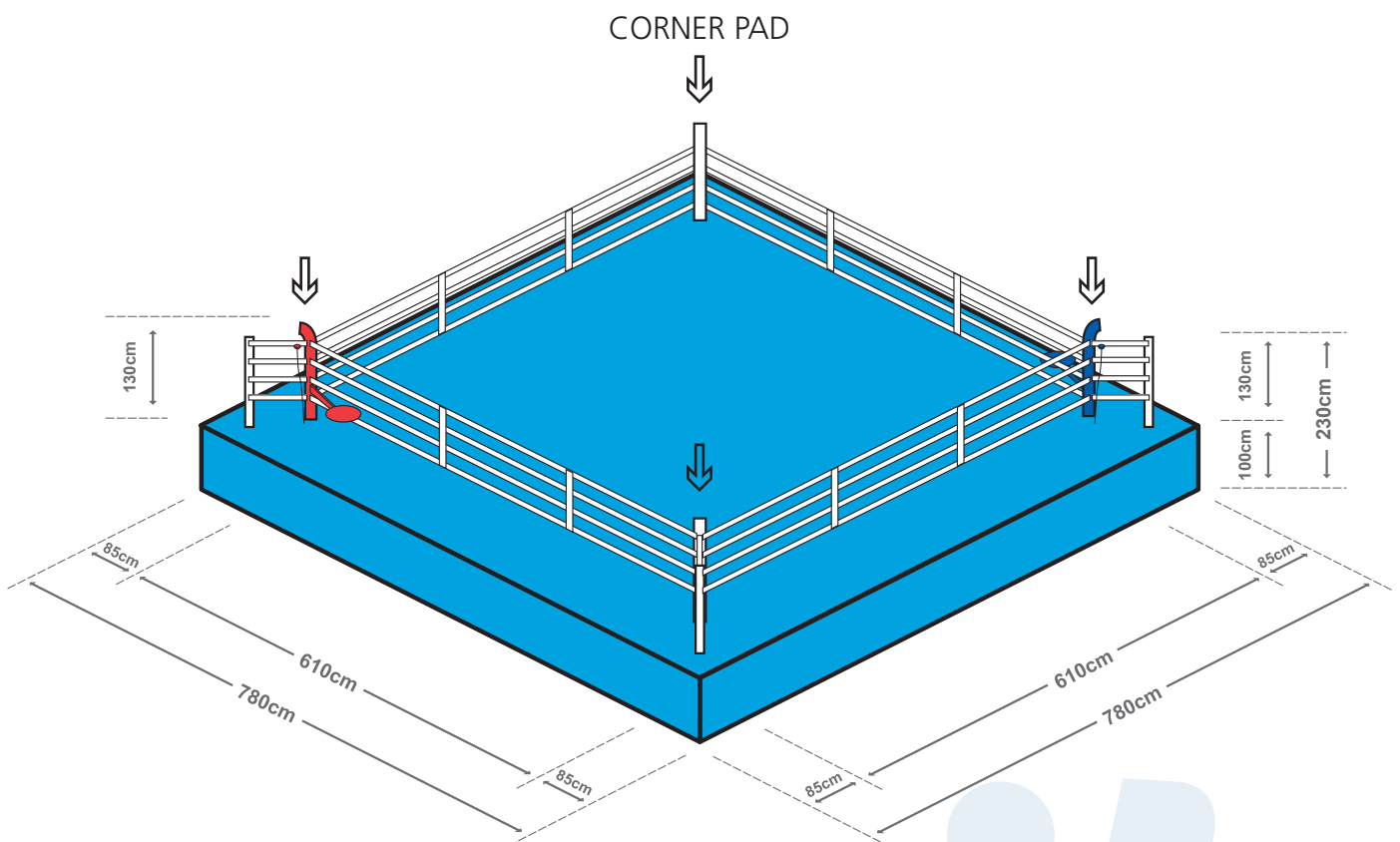

POLES

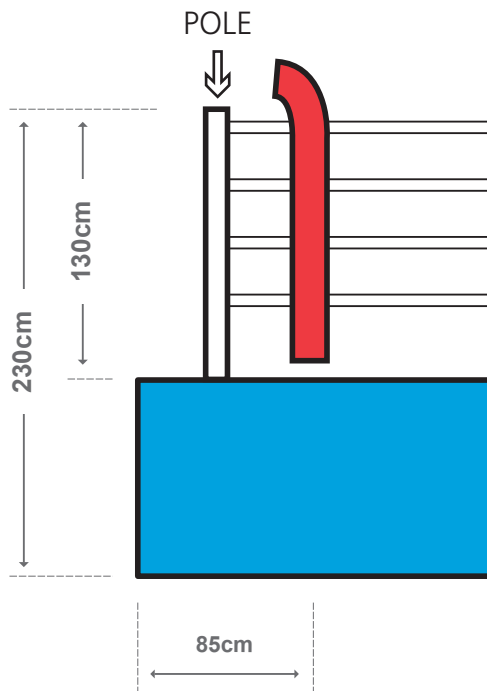

POLES SPECIFICATIONS:

- The total height of the poles should be 230cm
- The height above the canvas should be 130cm
- The bottom part of each pole should be covered by foam (1m from the ground) and there should be a steel pole inside the form
- The location of the poles should be 35cm inside the edge of the ring

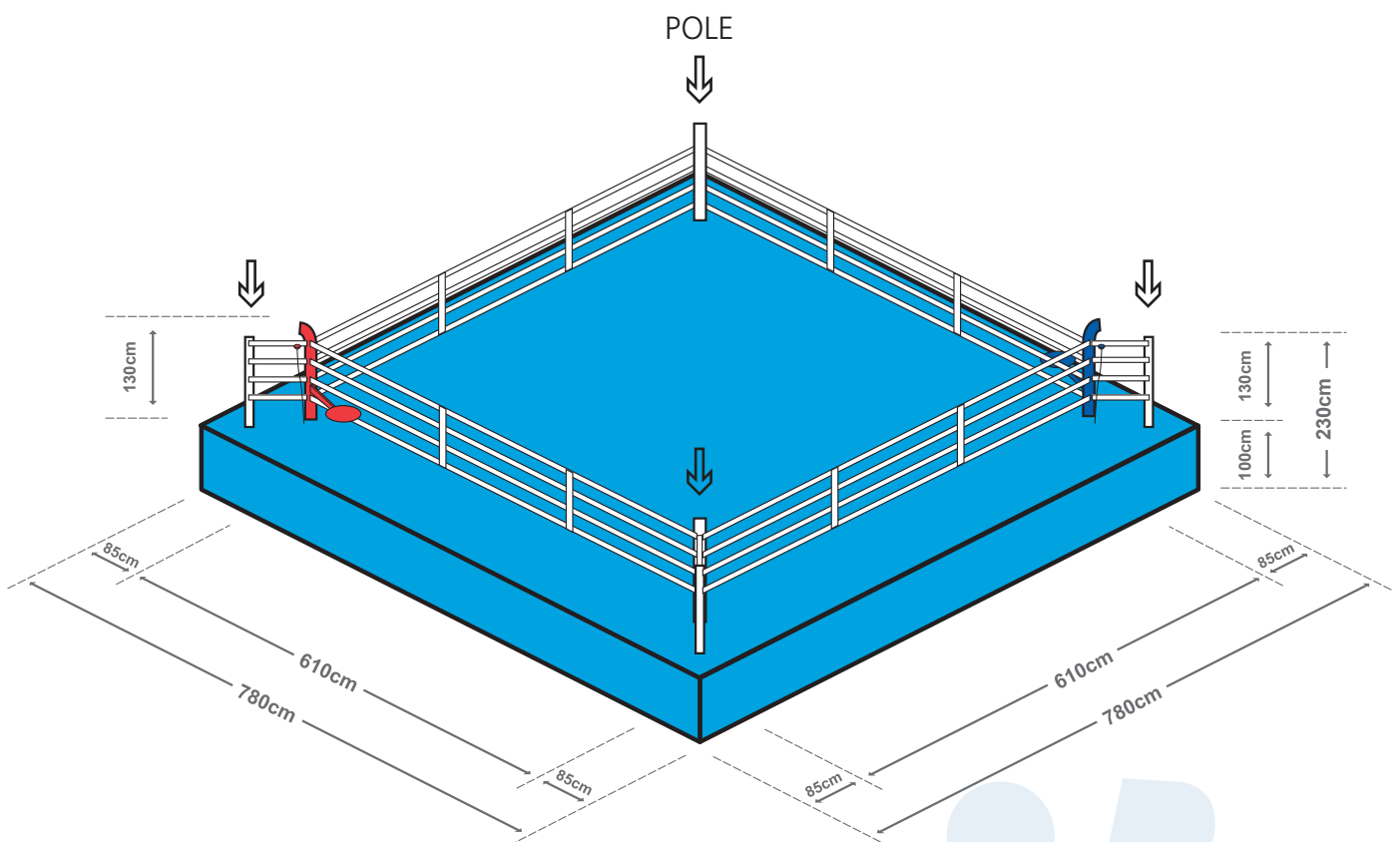

ROPES

ROPES SPECIFICATIONS:

- The ropes must be covered by a thick padding
- The ring must include four (4) separate ropes on each side of the corner posts. They must be 4cm thick, without considering the cover
- The heights of the four (4) ropes must be 40cm, 70cm, 100cm, and 130cm from the canvas
- The material of all rope covers should be Tapoline
- Ropes should be white
- The tension of each section of the top two ropes must be tight enough. The tension of bottom two must not be too tight

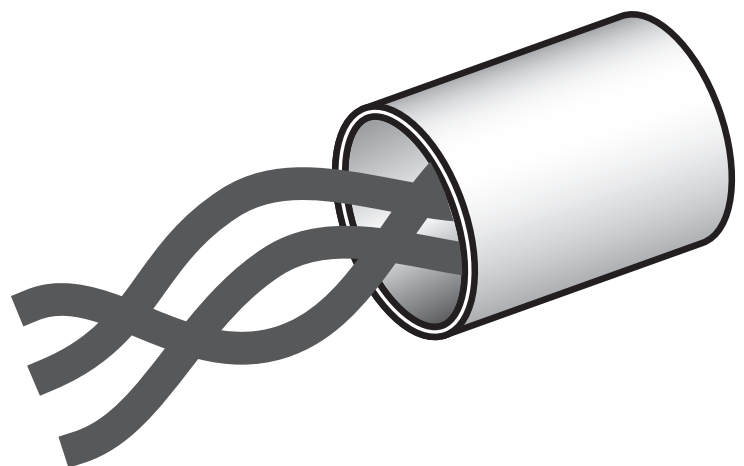
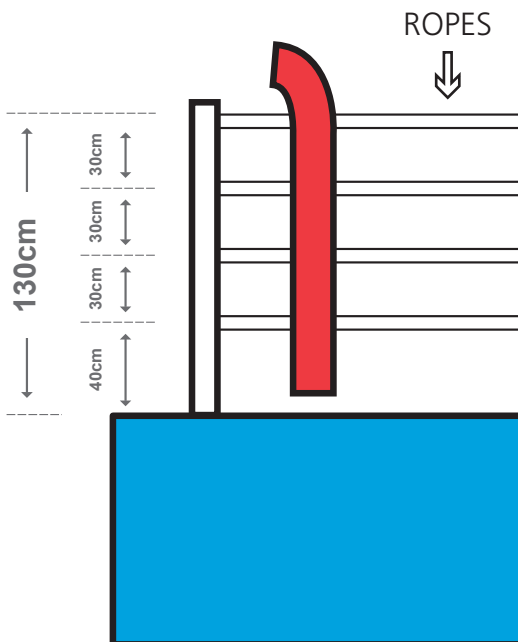
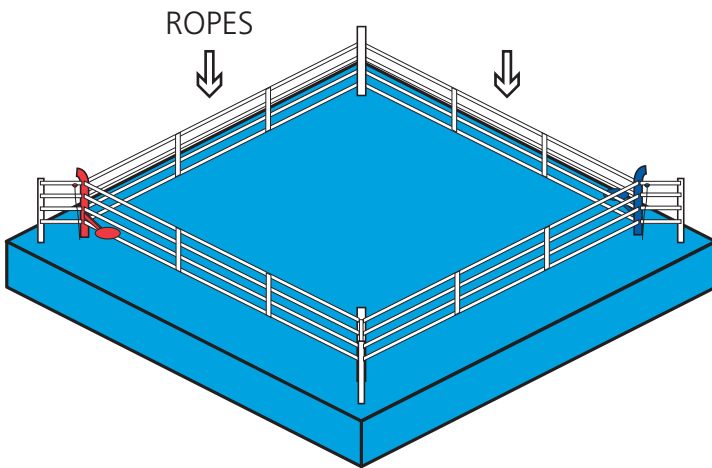

ROPE STRIPES

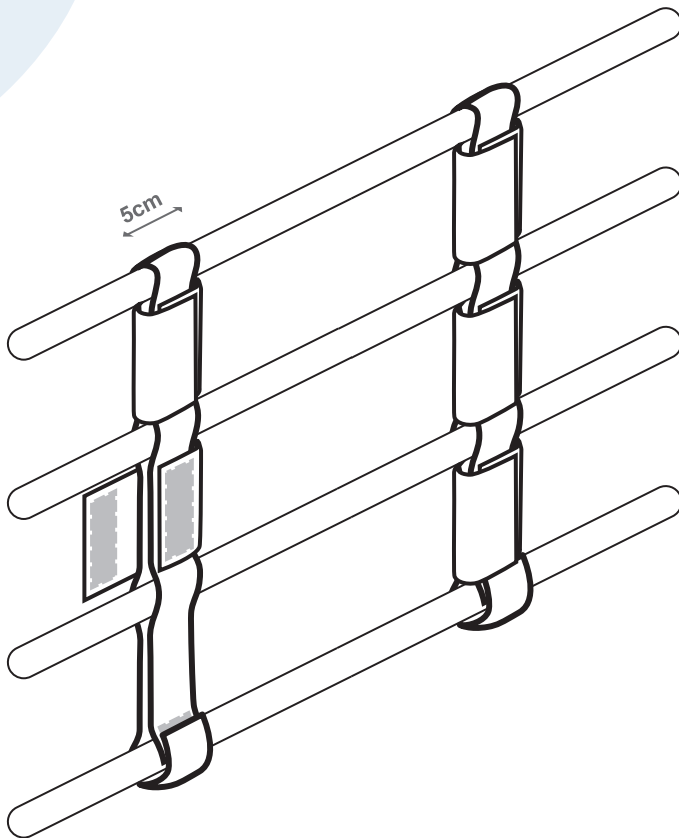

ROPE STRIPES SPECIFICATIONS:

- The four (4) ropes must be joined on each side of the ring, at equal intervals, by two (2) pieces of material (close to the texture of the canvas) 3 to 4cm wide
- The two (2) pieces must not slide along the rope
- In addition to the stripes, there should be 3 Velcro stripe holders
- The color of all stripes and of the Velcro stripe holders should be white
- The material of all stripes should be Tapoline

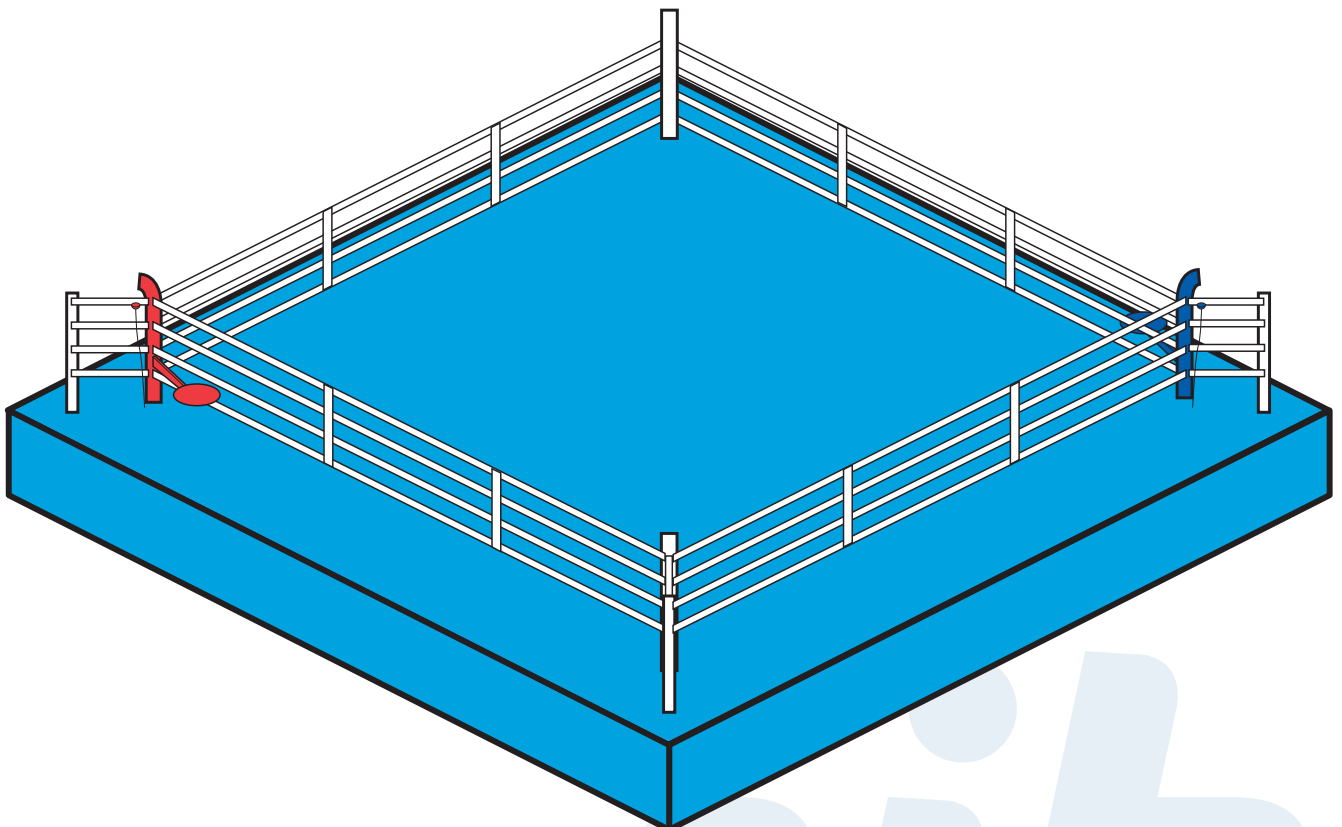

STAIRS

STAIRS SPECIFICATIONS:

- The stairs should have only 3 steps
- There should be 3 stairs
- The color of the 3 stairs should be: one red (PANTONE 185C), one blue (PANTONE 286C) and one white
- The total height of the stairs should be 75 cm
- The width of the steps should be 80cm
- The angle of inclination of the steps should be 54 degrees
- The stairs should be made of FRP material
- The steps should be antislippery
- The stairs must not be fixed to the ring
- The stairs must be moveable

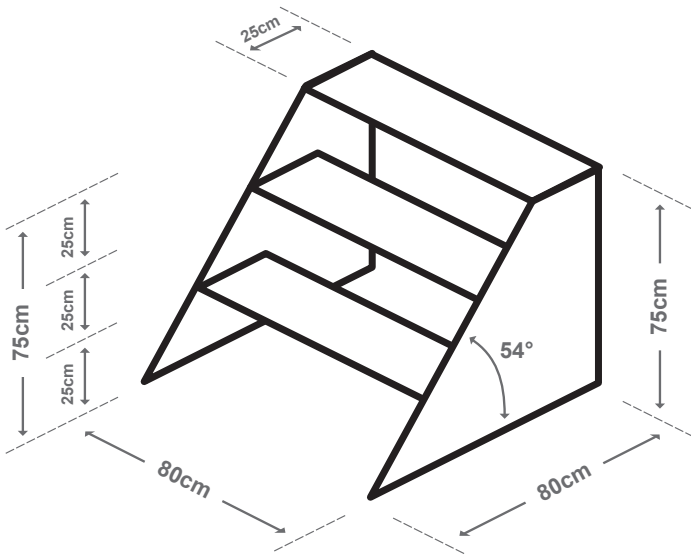

ANTISLIPPERY SURFACE

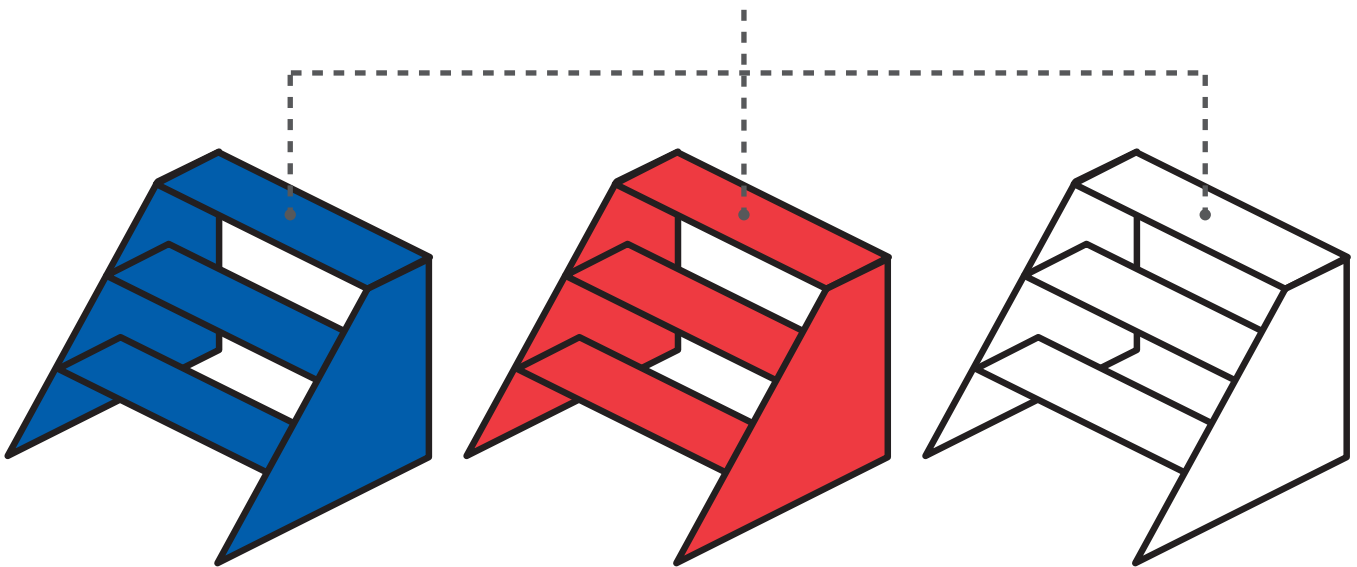

CORNER'S CHAIR

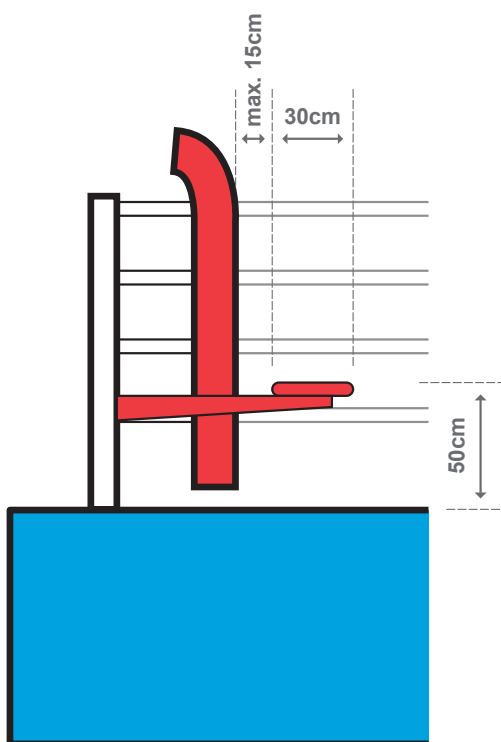

CORNER'S CHAIR SPECIFICATIONS:

- The two corner chairs must be swing chairs to come in and out of the ring by being attached to the poles
- Each chair must be displayed in blue (PANTONE 286C) or red (PANTONE 185C) according to their respective corner color
- The maximum distance between the chairs and the corner pads is 15cm
- The diameter of each chair should be 25cm

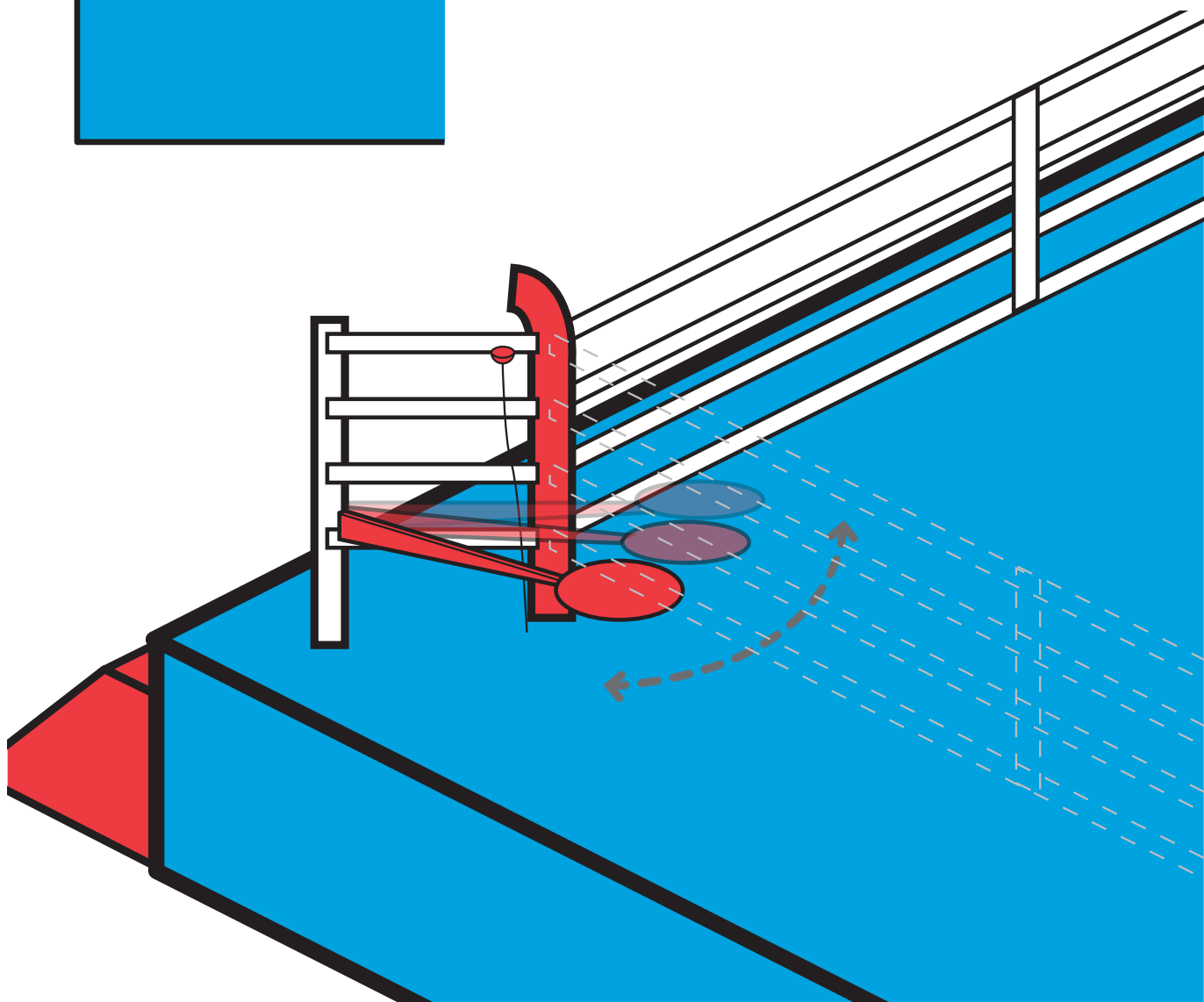

SPIT CONTAINERS

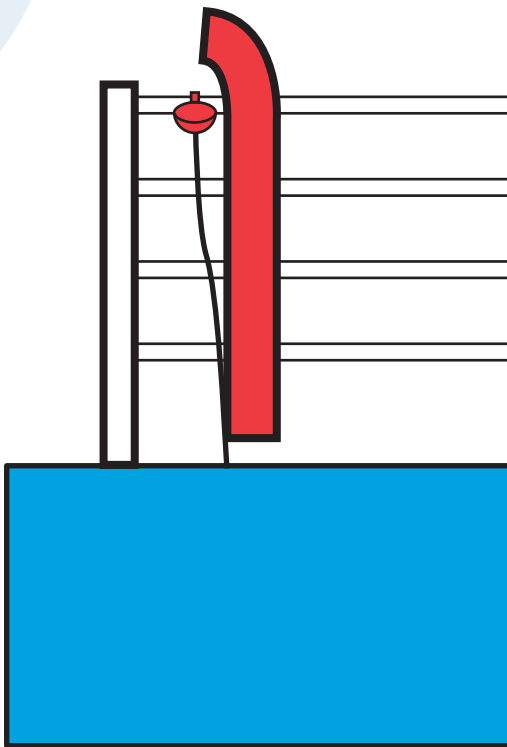

SPIT CONTAINERS SPECIFICATIONS:

- The container should be made of plastic material and displayed in red (PANTONE 185C) or blue (PANTONE 286C) color
- The maximum dimension is 25 centimeters
- The diameter of the container's tube must not be larger than 15 millimeters
- The hose (or pile) must be attached to the pole or ropes and be removable
- The hose should be colorized according to the red and blue corner

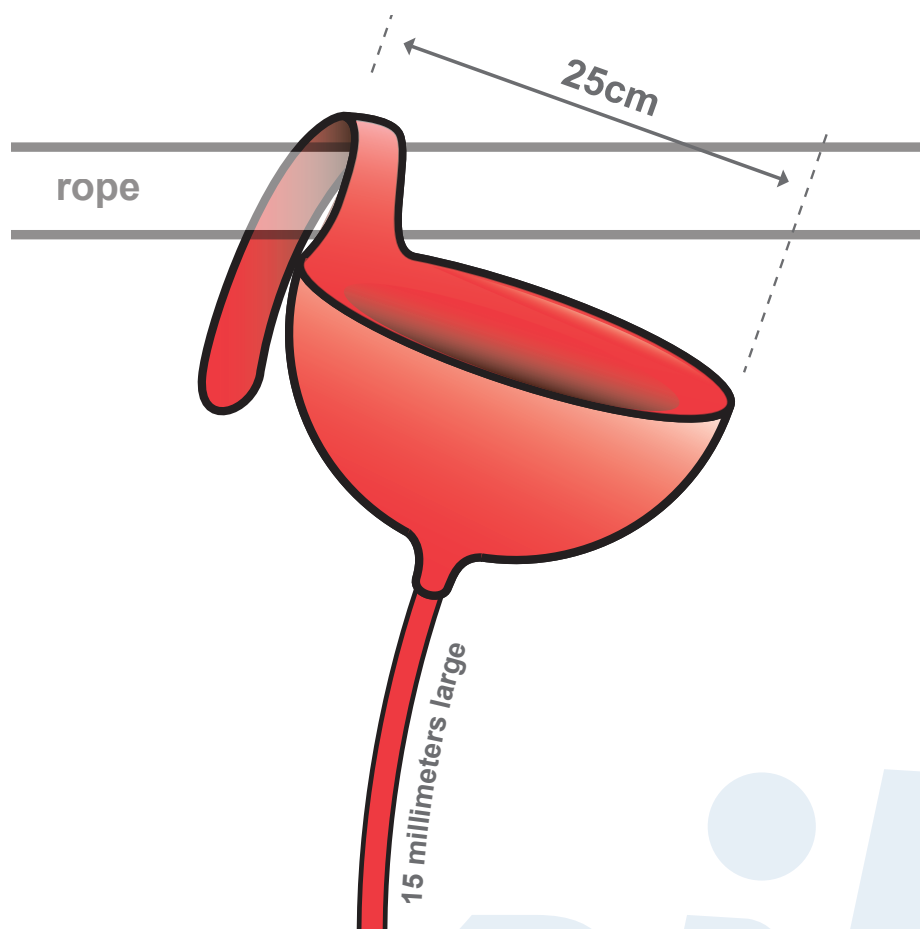

LOGO AND PRINT

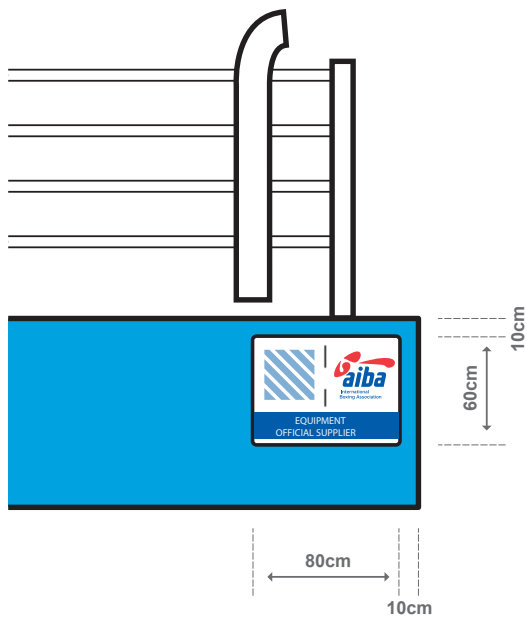

LOGOS & PRINT SPECIFICATIONS:

- only one manufacturer logo can be displayed at the neutral corner, where there's no stairs
- Maximum size of manufacturer logo is 25cm x 25cm (625cm²)
- Equipment Official Supplier layout will be provided by AIBA
- Any Event logo shall be print on the middle of the Canvas. In case of no event, please consult with AIBA what to print
- Event logo maximum size is 200 x 200 cm

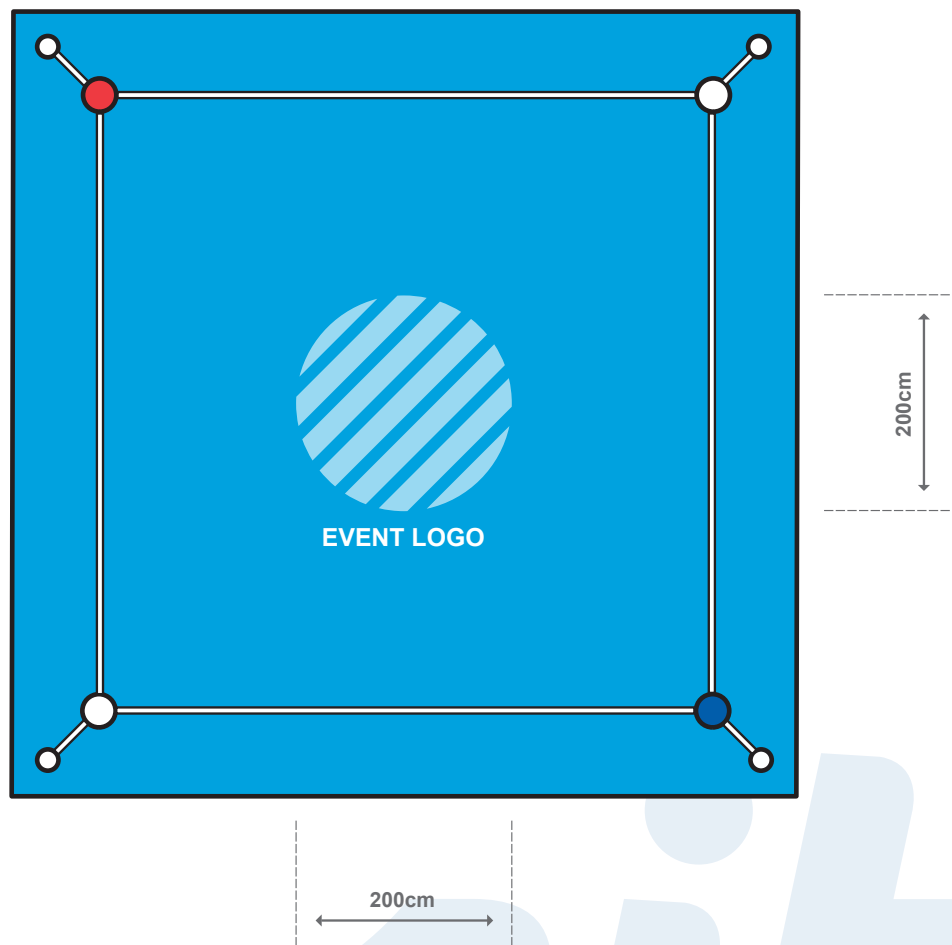

STORAGE BAGS

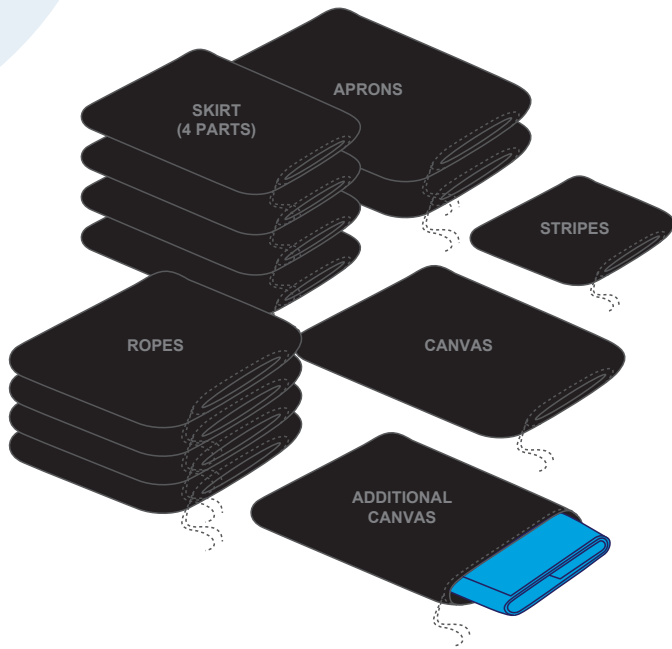

STORAGE BAGS SPECIFICATIONS:

- The following parts should be stored properly in each storage bag with serial numbers
 - o 1 ring skirt (4 parts)
 - o 2 canvas
 - o 2 apron
 - o 4 ropes
 - o 8 stripes with Velcro stripe holders

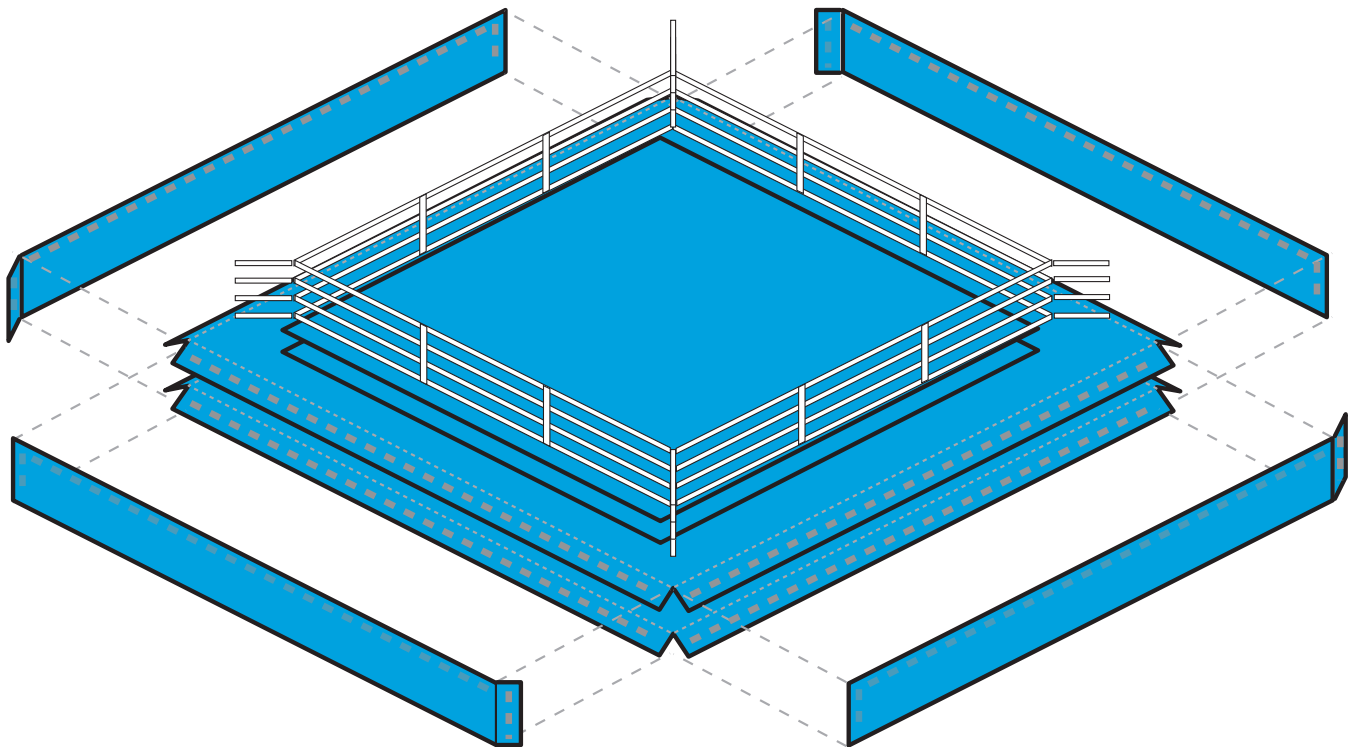

ASSEMBLY GUIDELINES



ASSEMBLY GUIDELINES:

- An introduction booklet for assembling the ring should be included in all 5 AIBA languages and this for all AIBA rings – English, Spanish, Russian, Arabic and French

